

# NEO-700111

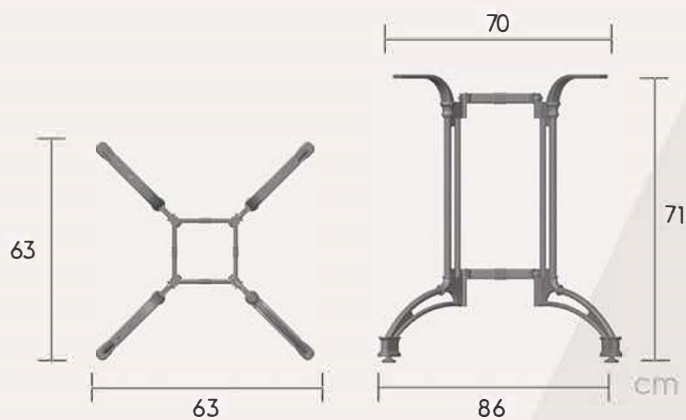

RECYCLABLE PRODUCT



DISASSEMBLED



ADJUSTABLE FEET

## MATERIAL

• Aluminum high pressure die casting.  
4-legs

## COLOR OPTIONS



White



Black



Others

Finishing: Powder coating  
Standard Colors: Black & white.  
Any specific colours are available with MOQ-100 pcs.



## BOX DIMENSIONS



PCS/BOX	LENGTH (cm)	WIDTH (cm)	HEIGHT (cm)	NET WEIGHT (kg)	GROSS WEIGHT (kg)	VOLUME m <sup>3</sup>
1 pcs	74,5	33,0	8,5	5,49	6,00	0,021

## LOGISTIC INFO

1.092 pcs



2.340 pcs



2.574 pcs

