

NEO-700500

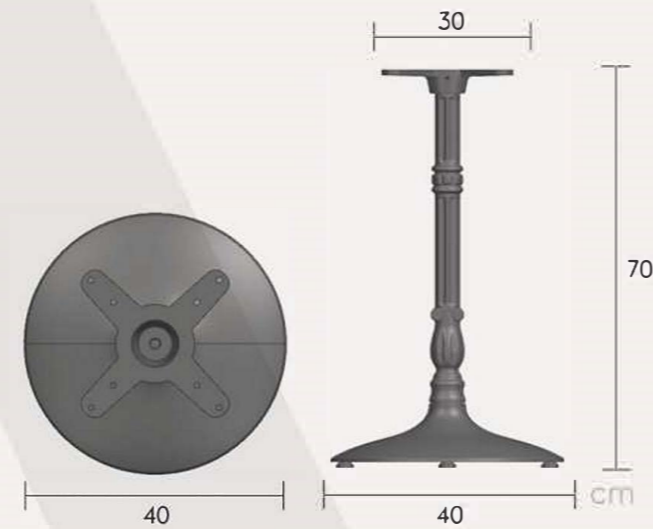

MATERIAL

• Aluminum high pressure die casting

COLOR OPTIONS

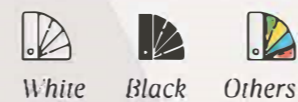

Finishing: Powder coating
Standard Colors: Black & white.
Any specific colours are available with MOQ-100 pcs.



BOX DIMENSIONS

PCS/BOX	LENGTH (cm)	WIDTH (cm)	HEIGHT (cm)	NET WEIGHT (kg)	GROSS WEIGHT (kg)	VOLUME m ³
1 pcs/	42,0	40,5	13,5	6,55	7,08	0,026
2 box	73,0	6,5	7,0			

LOGISTIC INFO



TECHNICAL INFORMATION

- Surface treatment processes • Precisely CNC machined • Outdoor
- Foldable • Corrosion Resistance • Coated with electrostatic powder
- Adjustable table level for rough floors



COATING

Electrostatic powder coating with certified class 1 high quality chemicals from top brands.

COLOR OPTIONS



MAINTENANCE

It is recommended to clean the products regularly especially in humid or marine climate locations to keep them in good condition for a long time. Clean the surfaces using a soft cloth with water or mild detergents. Prolonged and continuous exposure to intense UV radiation from sunlight or very low temperatures can negatively affect the coating therefore to keep products in sheltered places during non-use periods is strongly recommended.

CERTIFICATIONS

This powder coating complies with the European Directives "Restriction of the use of certain hazardous substances" 2011/65/EU and 2015/863/EU (RoHS)

Meets the requirements of AAMA 2603-15

Meets the requirements of EN 12206-1 (formerly BS 6496), EN 13438 (formerly BS 6497)

Classification A2 (non flammable) of reaction to fire in accordance with NF EN 13501-1 + A1: 2013

QUALCOAT

Class 1: P-0145, P-0846, P-0673, P-0800, P-1661

GSB INTERNATIONAL

Florida 1: 171e

MARINE

CE 0575, CE 2690



ADJUSTABLE FEET CAP