

NEO-700510

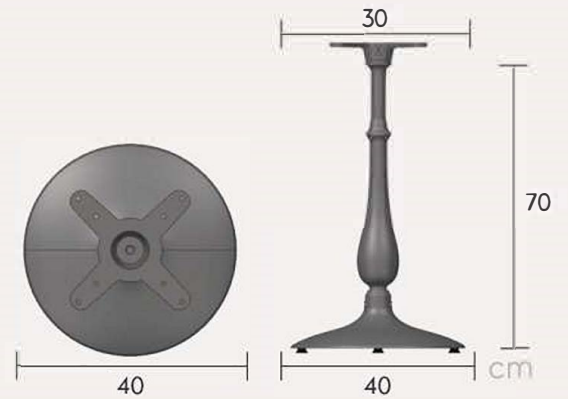

 RECYCLABLE PRODUCT

 DISASSEMBLED

 ADJUSTABLE FEET

MATERIAL

• Aluminum high pressure die casting

COLOR OPTIONS

 White  Black  Others

Finishing: Powder coating
Standard Colors: Black & white.
Any specific colours are available with MOQ-100 pcs.



BOX DIMENSIONS



PCS/BOX	LENGTH (cm)	WIDTH (cm)	HEIGHT (cm)	NET WEIGHT (kg)	GROSS WEIGHT (kg)	VOLUME m ³
1 pcs/ 2 box	42,0	40,5	13,5	7,63	8,23	0,030
	59,5	10,5	10,5			

LOGISTIC INFO

1.008 pcs 

2.160 pcs 

2.376 pcs 