

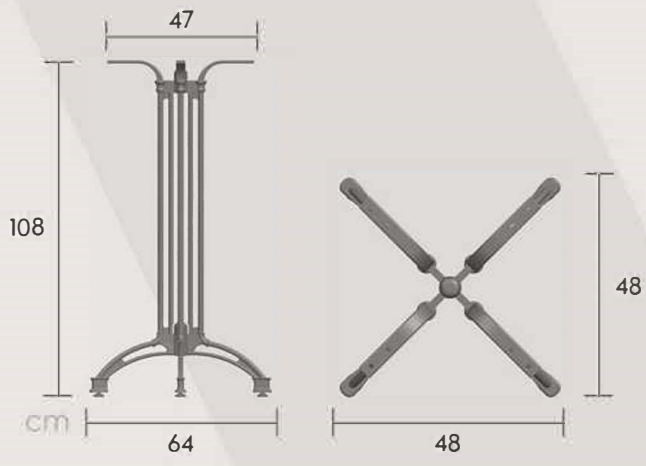

# NEO-701003



-   
 RECYCLABLE PRODUCT
-   
 DISASSEMBLED
-   
 ADJUSTABLE FEET

**MATERIAL**  
 • Aluminum high pressure die casting, 4-legs

**COLOR OPTIONS**  
 White Black Others

 *Finishing: Powder coating*  
*Standard Colors: Black & white.*  
*Any specific colours are available with MOQ-100 pcs.*

 **BOX DIMENSIONS**

PCS/ BOX	LENGTH (cm)	WIDTH (cm)	HEIGHT (cm)	NET WEIGHT (kg)	GROSS WEIGHT (kg)	VOLUME m <sup>3</sup>
1 pcs	110.0	33.0	13.0	5.75	6.40	0.047

**LOGISTIC INFO**

- 450 pcs 
- 1.080 pcs 
- 1.170 pcs 

