

NEO-708103

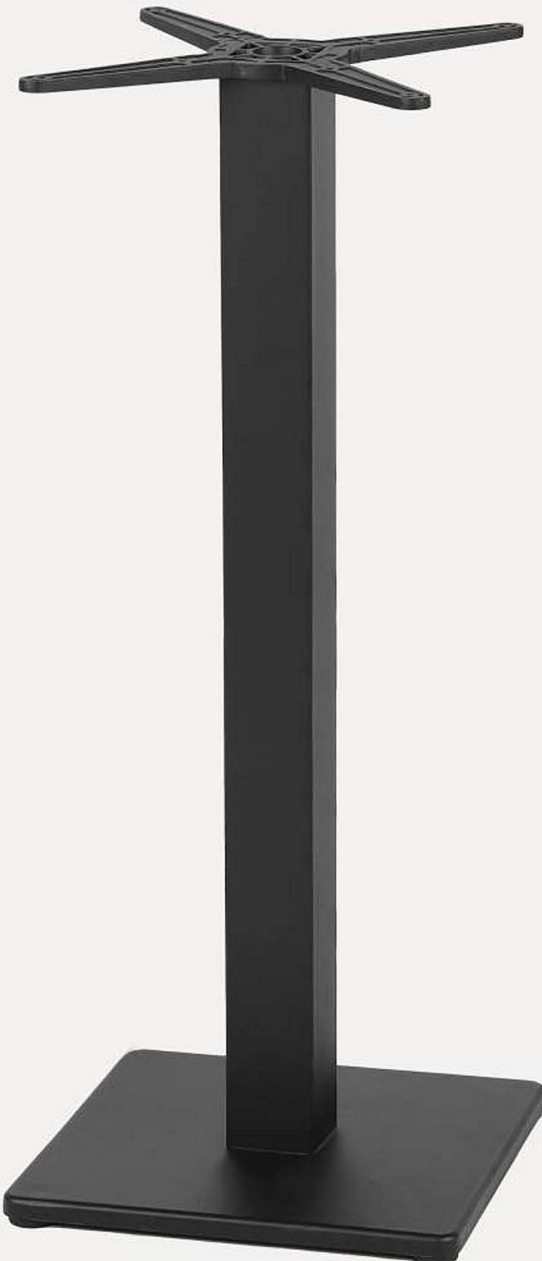
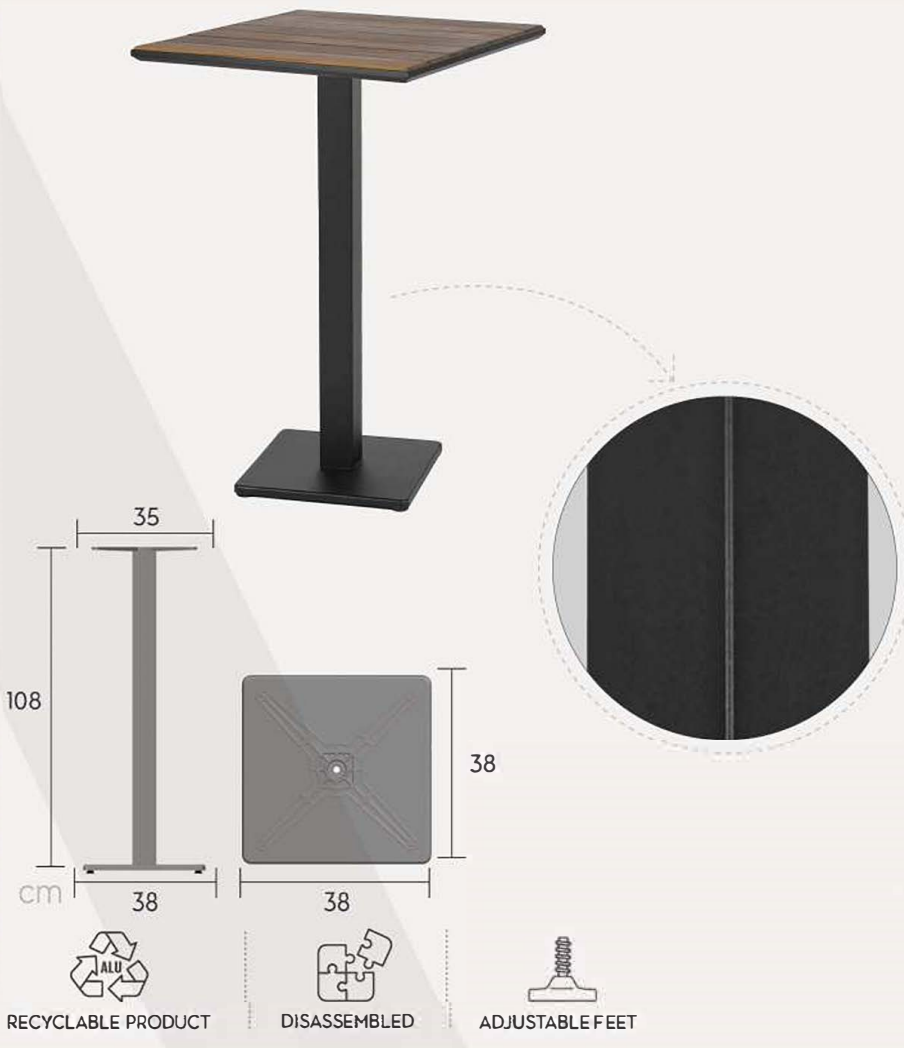

MATERIAL

• Column 80x80 mm aluminum extrusion, base & cross high pressure die casting

COLOR OPTIONS



Finishing: Powder coating
Standard Colors: Black & white.
Any specific colours are available with MOQ-100 pcs.



BOX DIMENSIONS

PCS/ BOX	LENGTH (cm)	WIDTH (cm)	HEIGHT (cm)	NET WEIGHT (kg)	GROSS WEIGHT (kg)	VOLUME m ³
1 pcs/ 2 box	43,0	43,0	4,0	7,47	8,37	0,017
	108,0	9,5	9,5			

LOGISTIC INFO

